

TABLE OF CONTENTS

Table Of Contents	1
Foreword	1
Opening Framing Diagram	2
Gasket Installation Diagrams	3
Door Assembly Instructions	4
Door Assembly Diagrams	5
Winch End Assembly	6
Counterweight End Assembly	7

Foreword:

In order to assure proper performance and smooth functioning of the system the installer must understand importance of quality construction and use of straight quality materials. Through out this manual specific cautions relating to performance of the system will be noted.

The tunnel door opening should be flat in the vertical and horizontal planes. The framed opening should be level to a tolerance of plus 1/4" to minus 1/4". From end to end out of level should be less than 1/2". The use of optical level is suggested for determining level tolerance of the opening. Particular attention should be given to level installation of top stringer and hinge board. The use of a string line to assure horizontal straightness is suggested. Square corners should be maintained. Sealing and caulking around framing members is critical for proper door performance. See page 2 for framing details.

Gasket installation to follow caulking. Reference page 3 for details and instructions for gasket installation. Prior to fastening the gaskets the full length should be unrolled and checked for twist, possible tears, or other damages. Note interference fit between bottom P-Seal and side P-Seal. Figure 1 on page 3.

Door installation to follow gasket installation. Page 4 explains door assembly. Page 5 provides visual aids for door installation. Two important points concerning door installation. First: Be careful when positioning door panels on bottom P-Seal to avoid damaging seal. Second point would be the importance of installing the first door panel level. This point can not be over emphasized.

As the door installation continues the weight of the assembly will require tying off for safety. Spacing between Tie-Offs to be less than 25' apart. See sketch below for Tie Off detail.

Following the installation of the doors. The Winch End (Page 6) and Counterweight (Page 7) to be installed. With the control cable in place and tensioned the door rope installation can be completed. Final adjustment of the doors will be accomplished when tension in the door ropes seals the door assembly to the gaskets.

Final adjustment of system is complete with smooth operating of the system.

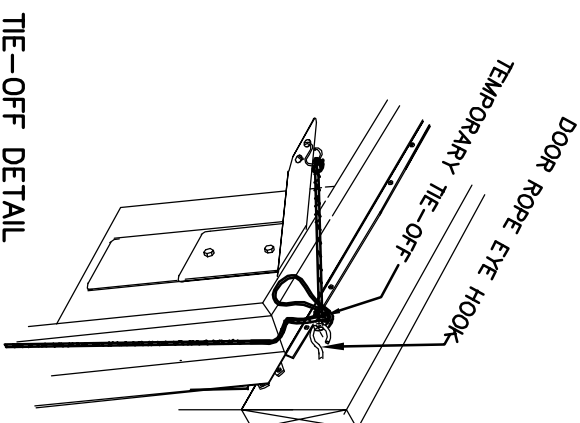

TIE-OFF DETAIL

GENERAL FRAMING DIAGRAM

A = 3" LESS THAN TUNNEL DOOR HEIGHT
 B = 3" LESS THAN TUNNEL DOOR OPENING

STRINGERS TO BE INSTALLED STRAIGHT. THEREFORE SELECT QUALITY LUMBER. THEN SHIM, SHAVE ETC. AS REQUIRED TO PROVIDE LEVEL AND STRAIGHT STRINGER. USE STRING LINE TO VERIFY STRAIGHTNESS. SEE Foreword: PAGE 1 FOR SUGGESTED LEVEL TOLERANCES.

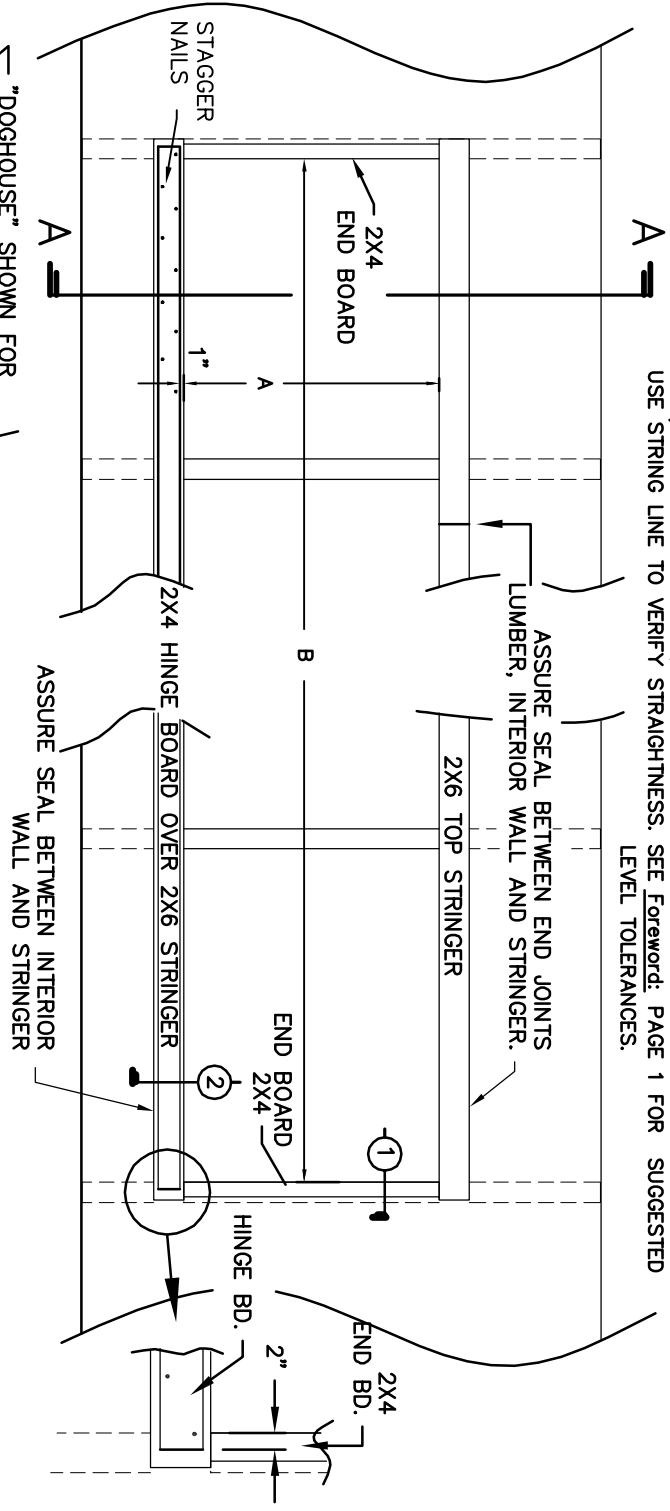

TYPICAL FRONT VIEW FRAMING ELEVATION

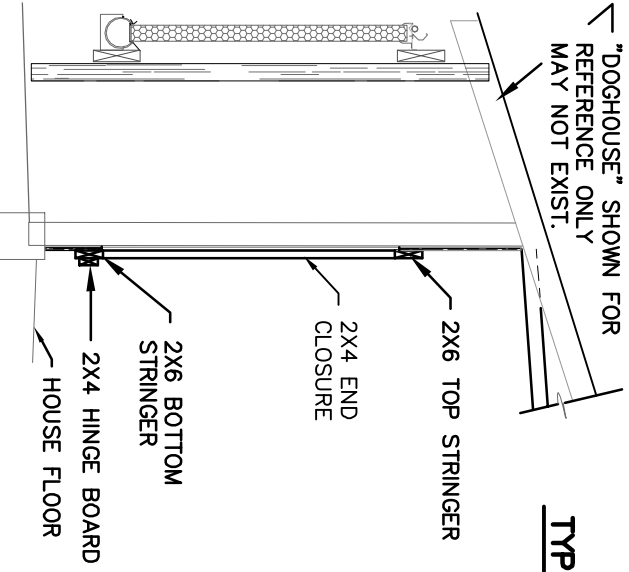
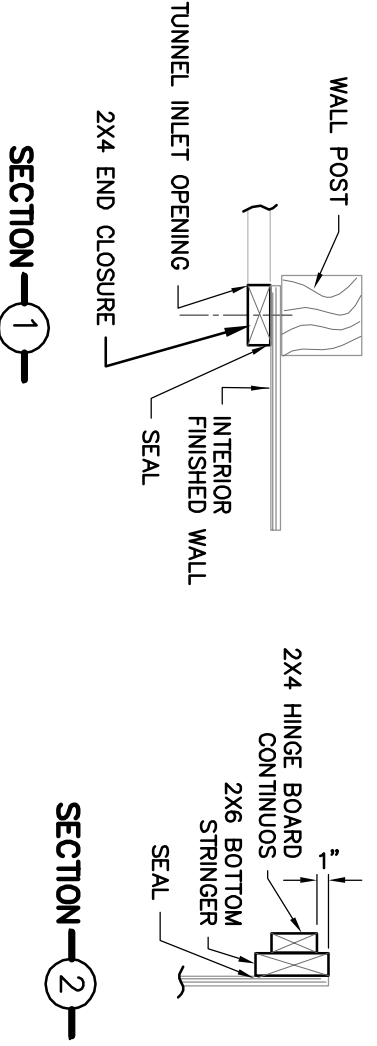

GENERAL FRAMING SECTION A-A

GASKET INSTALLATION DETAILS

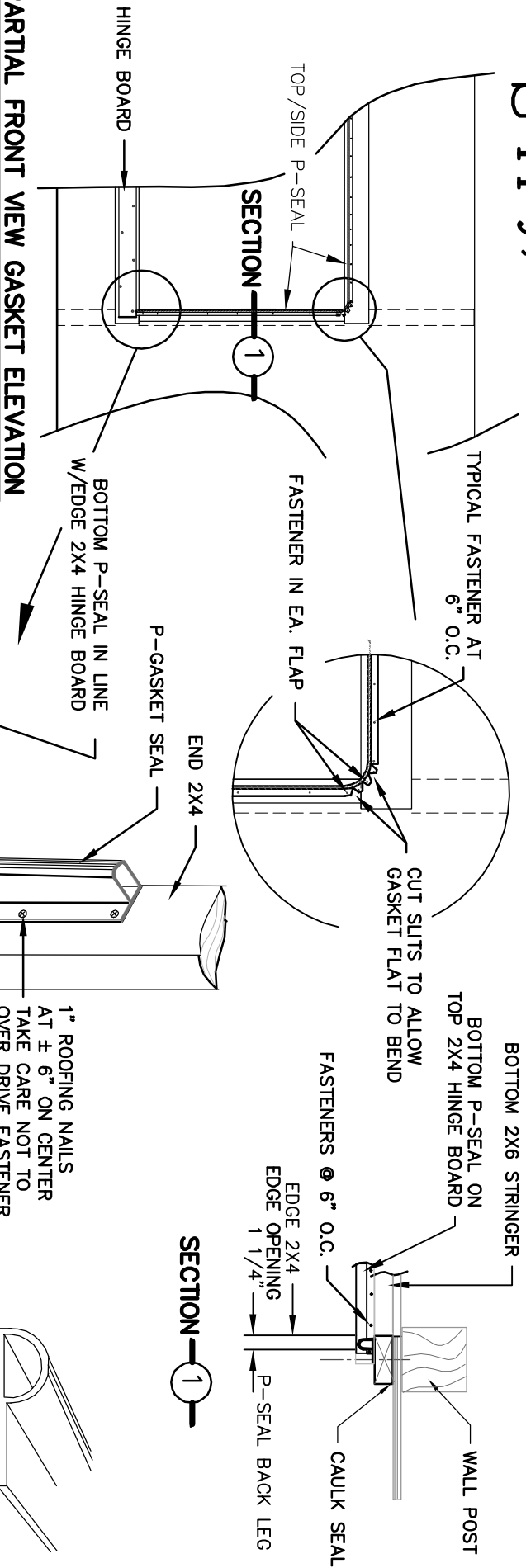

BOTTOM P-SEAL

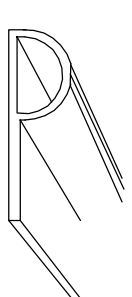

TOP/SIDE P-SEAL

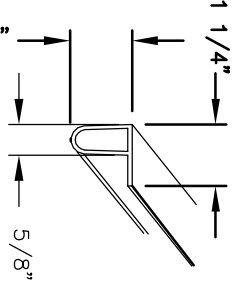

GASKET INSTALLATION

Roll out bottom P-Seal the length of the tunnel door opening plus 4". This provides 2" beyond each side opening. Line up bulb with face of the hinge board and fasten one end. Verify the seal is free of twist. Take care to straighten the seal before attaching to the hinge board. If the seal is stretched out to help with the lining up of seal the seal should be allowed to shrink back to original length before nailing. Continue fastening bottom seal with bulb lined up with face of the hinge board using 1" roofing nails at approximately 6" on center. Avoid over sinking the nails.

Install ends and top P-Seal.

Unroll side and top P-Seal material the length of the tunnel doors plus 12 feet. Again verify the material is not twisted. Start with the edge of the bulb flush with the tunnel opening and the top of the bulb flush with the back of the bottom P-Seal. The side/top P-Seal is to be tightly compressed against the bottom seal. Use 1" roofing nails at approximately 6" on center. Cut slits in flats to allow turning at corners.

FIGURE - 1

DOOR ASSEMBLY INSTRUCTIONS

SEE PAGE 3 FOR P-SEAL DETAILS
SEE PAGE 5 FOR DOOR ASSEMBLY DIAGRAMS

INSTALLING TUNNEL DOORS

Before starting the tunnel door installation verify gaskets seals are properly installed, anchored and without twist, rolls or tears.

Start with the End Door Panel. After the end handle with reinforcing plate has been mounted it is time place this door panel in place on the bottom P-Seal. Reference page 5 for detail on installing end handle w/reinf. pl. Carefully lift and place end door on bottom P-Seal. The bottom P-Seal will slightly deform. If the door needs lateral placement slightly lift and slide to avoid tearing the bottom seal.

After positioning the door on the bottom P-seal one person to level and slightly depress the bottom seal. While the door is held in position another to fasten hinge to the hinge board using 2 each 3/8"Ø x 1 1/2" lg. wood screws. Verify the door panel is level. Do not over tighten the screws.

Installing the second door panel. Again carefully lift and place door on bottom seal. Verify second door is properly placed against first door with full flange lap. While one slightly depresses and levels 2nd door with first door another installs 3 ea. 5/16" x 3/4" lg. self tapping Tec screws. 1 screw about 3/4" up from bottom 2nd about 3/4" down from top and 3rd near center. Now the hinges can be fastened to hinge board. Check for level before anchoring hinges.

After installing a few of the panels the door weight becomes a factor. To safely support the door assembly temporary TIE-OFFs to be installed. Reference page 1 for Tie-Off details. Maximum Tie off spacing to be 25'.

Following completion of the door installation the door ropes and eye hooks to be installed. Centers of eye hooks to be 1" above the top of the door centered on the door handles. Reference page 6.

The winch end and counterweight should now be installed to allow for the routing of the control cable. See Page 6 for winch end details and Page 7 for the counterweight installation. At this time the control cable may be tensioned as required for attachment of door control ropes to the control cable.

After all door ropes have been routed through eye hooks and clamped to control cable with cable clamps it is time to adjust the tension in door ropes to control cable. The contact between the door and gasket can be checked by looking for light between gasket and door.

Rotate door rope eye hook $\pm 45^\circ$ to improve the slide of door rope in eye hook

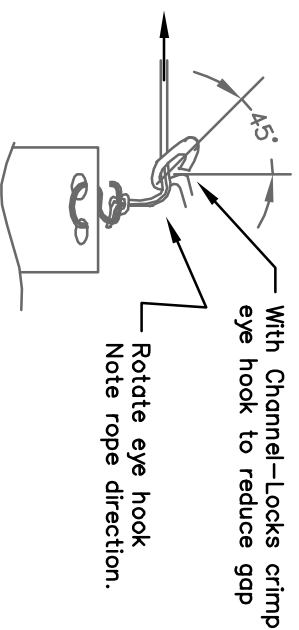

DOOR ASSEMBLY DIAGRAMS

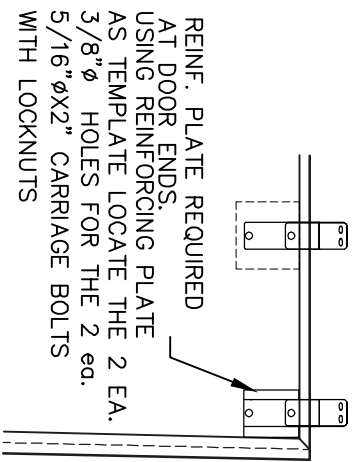
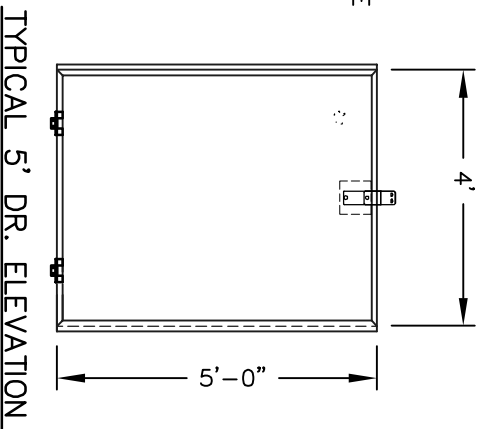
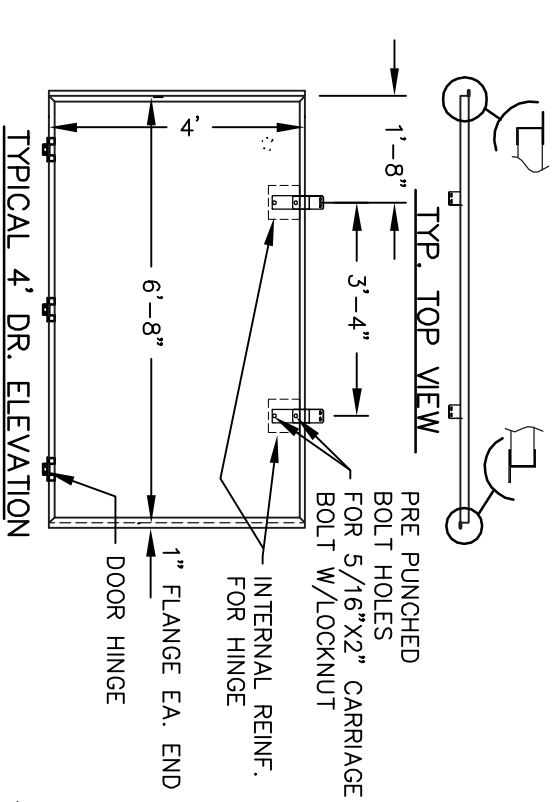

**TYPICAL END HANDLE
DETAIL**

NOTE: HANDLE WITH REINF. PLATE TO BE INSTALLED EACH END OF OVERALL DOOR ASSEMBLY

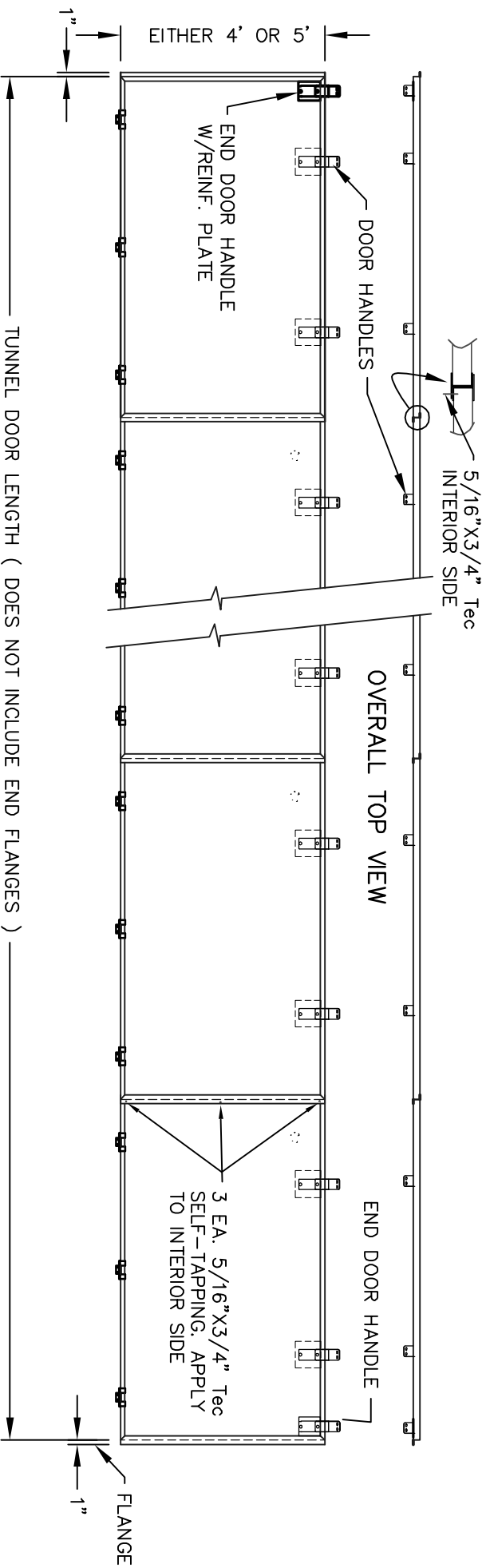

FASTEN FIRST THREE DOOR ROPES WITH FIRST DOOR ROPE CLAMP ONLY; REMAINDER ROPE CLAMPS SECURES ONLY TWO ROPES

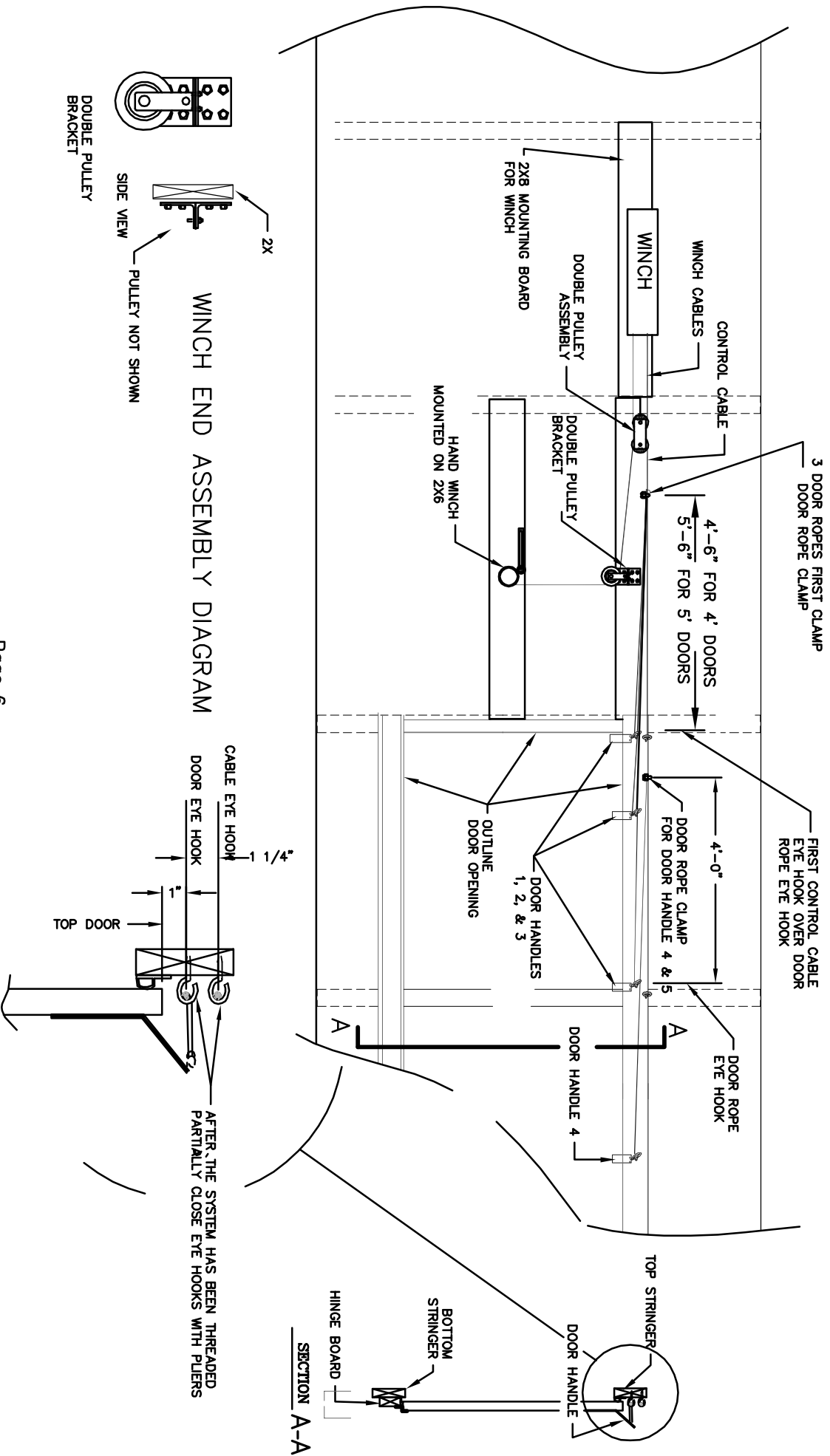

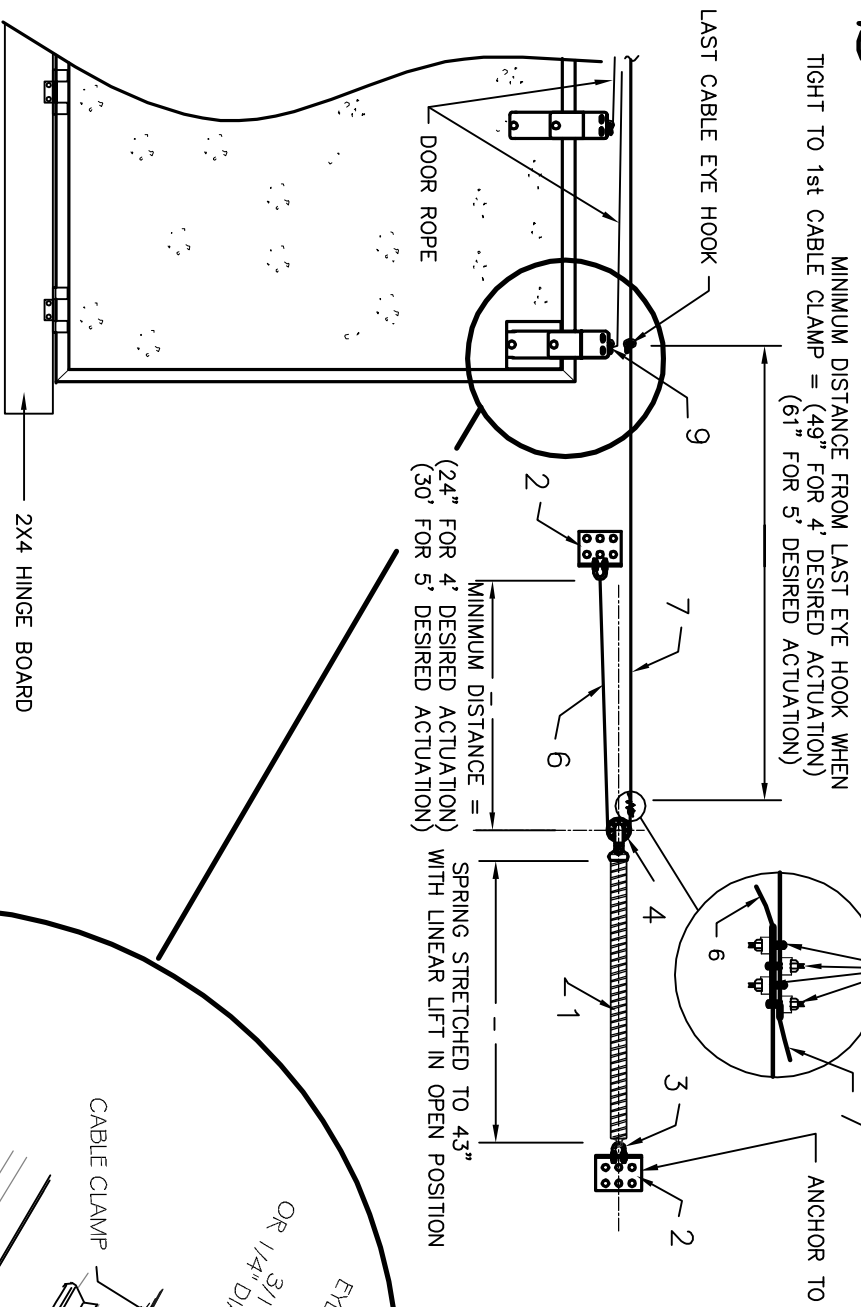

Item	Description
1	TENSION SPRING
2	PULLEY BRACKET
3	U-BOLT
4	PULLEY
5	BRASS NUT
6	COUNTERWEIGHT CABLE
7	CONTROL WIRE
8	CABLE CLAMP
9	LAST EYE HOOK

COUNTERWEIGHT SPRING INSTALLATION

Following installation of the counterweight and control wire the door ropes to be clamped to the control wire. Refer to Page 4 Door Assembly Instructions for final adjusting of the door rope.

